

RoHS

REV.	ECN NO	DESCRIPTION	REVISED	DATE
A		新订图面	KEVIN	2015. 03. 10

Specifications/技术规格:

Current rating: 3A (AWG#24)
 额定电流: 3A (AWG#24)
 Voltage rating: 250V AC, DC
 额定电压: 250V AC, DC
 Insulation Resistance: 1000MΩ Min.
 绝缘电阻: 最小1000MΩ
 Contact Resistance: 20mΩ Max
 接触电阻: 最大20mΩ
 Materials/材料:
 Contact Material: Phosphor Bronze
 接触端子材料: 磷铜

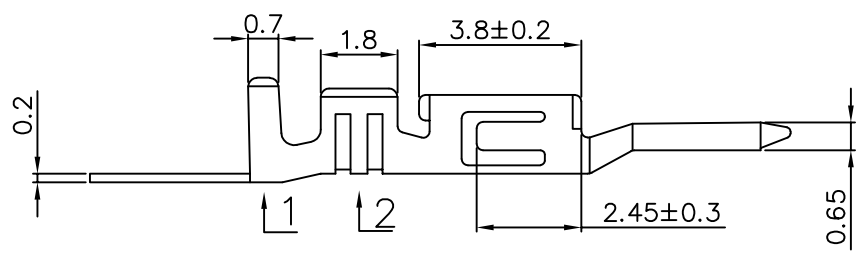

X ←

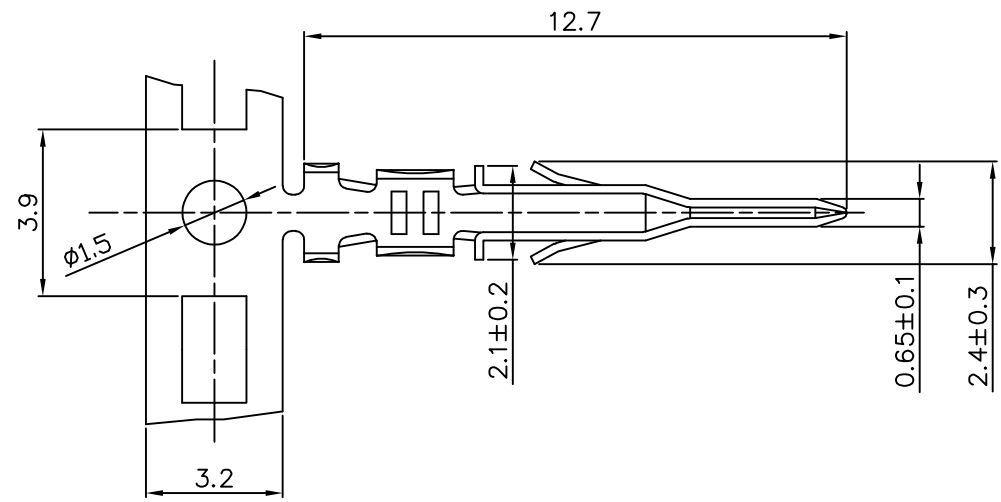

X向

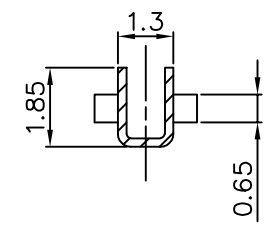

1-1

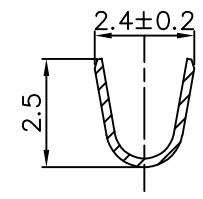

2-2

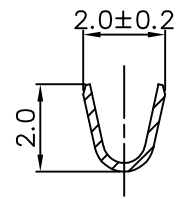

浙江快利电子有限公司
 Zhejiang Kuaili Electronic Co., Ltd

REV.	A	UNIT.	MM	SCALE.	1:1	
------	---	-------	----	--------	-----	--

GENERAL TOLERANCE	
X. ° ± 3°	.XXX ± 0.15
.X° ± 2°	.XX ± 0.25
.XX° ± 1°	.X ± 0.30
.XXX° ± 0.5°	X. ± 0.35

DESIGN:	王鑫	DATE:	2026. 1. 8
CHECKED:	朱继衡	DATE:	2026. 1. 8
AUDITED:	王子林	DATE:	2026. 1. 8
APPROVED:	朱建华	DATE:	2026. 1. 8

DWG. NO.	
PART NO.	KL-MX3. 0-AT

TITLE.	MX3. 0-AT
--------	-----------