

REV.	ECN NO	DESCRIPTION	REVISED	DATE
A		新订图面	KEVIN	2014.8.26

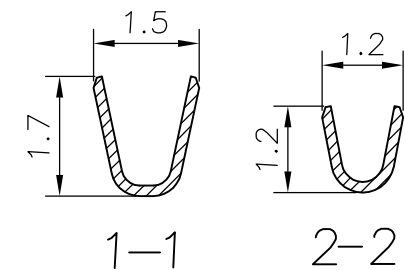

X向

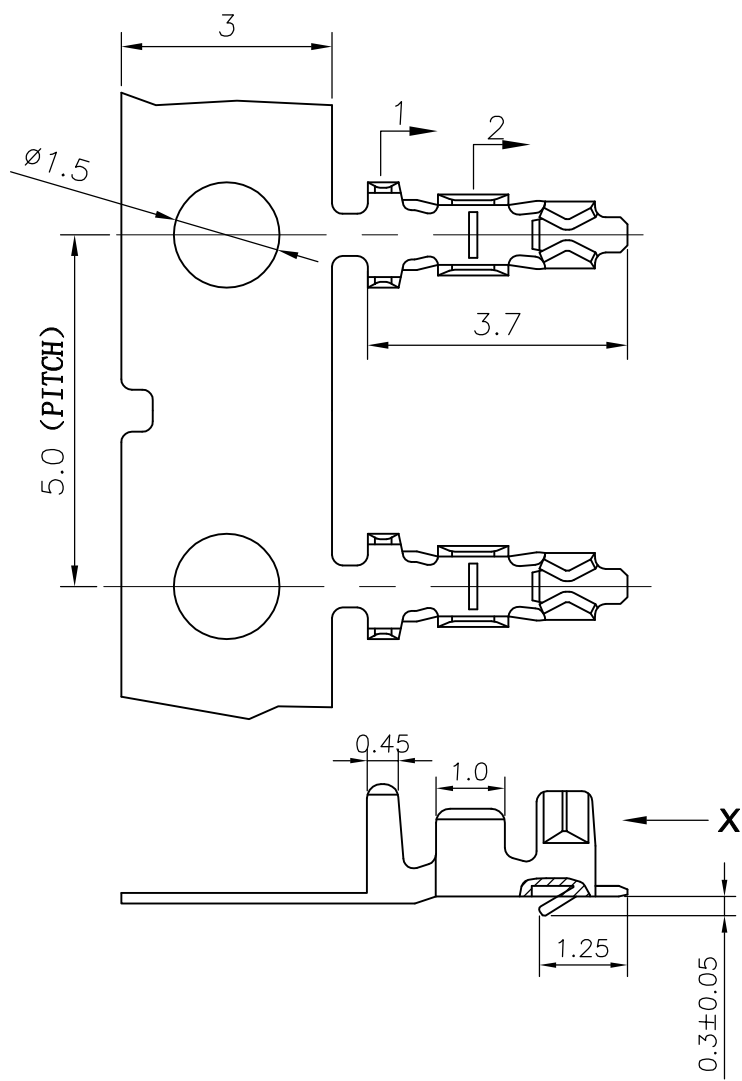
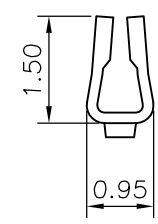

Specifications / 技术规格:

Current Rating: 1A
 额定电流: 1A
 Insulation Resistance: 500M Ω Min.
 绝缘电阻: 最小500M Ω
 Dielectric Withstanding: 500V AC
 耐压: 500V AC
 Contact Resistance: 20m Ω Max.
 接触电阻: 最大20m Ω
 Operating Temperature: -25°C to +85°C
 工作温度: -25°C 到 85°C

Materials / 材料:

Contact Material: Phosphor Bronze (Tin plating)
 接触端子材料: 磷铜 (镀锡)

浙江快利电子有限公司
 ZheJiang KuaiLi Electronic Co., LTD.

GENERAL TOLERANCE	
X.: 3 $^{\circ}$	X.: ± 0.35
.X.: 4 $^{\circ}$	X.X.: ± 0.25
.XX.: 5 $^{\circ}$	X.XX.: ± 0.15
.XXX.: 6 $^{\circ}$	X.XXX.: ± 0.10

DESIGN:	KEVIN	DATE:	2014-08-26
CHECKED:	李晓明	DATE:	2014-08-26
APPROVED:	朱建华	DATE:	2014-08-26

DWG. NO.	
PART NO.	KL-DF13-TE

TITLE.	DF13-TE
--------	---------

REV.	UNIT.	SCALE.	PAGE.	PROJ.
A	mm	-	1/1	